

EUROCOMACH MINI 14QLI ES14 SR4

Escavatore

Dati tecnici

Peso	1.255 Kg
Velocità massima	3,8 km/h
Numero di cilindri	3
Completo di 3 benne	



Escavatorie

Dati tecnici

Pendenza superabile	60% - 30°
Lunghezza braccio scavo standard (braccio optional)	1020 (1.150) mm
Larghezza cingoli	180 mm
Numero rulli (per ciascun lato)	3
Serbatoio gasolio	14,5 lt
Serbatoio olio idraulico	9,5 lt

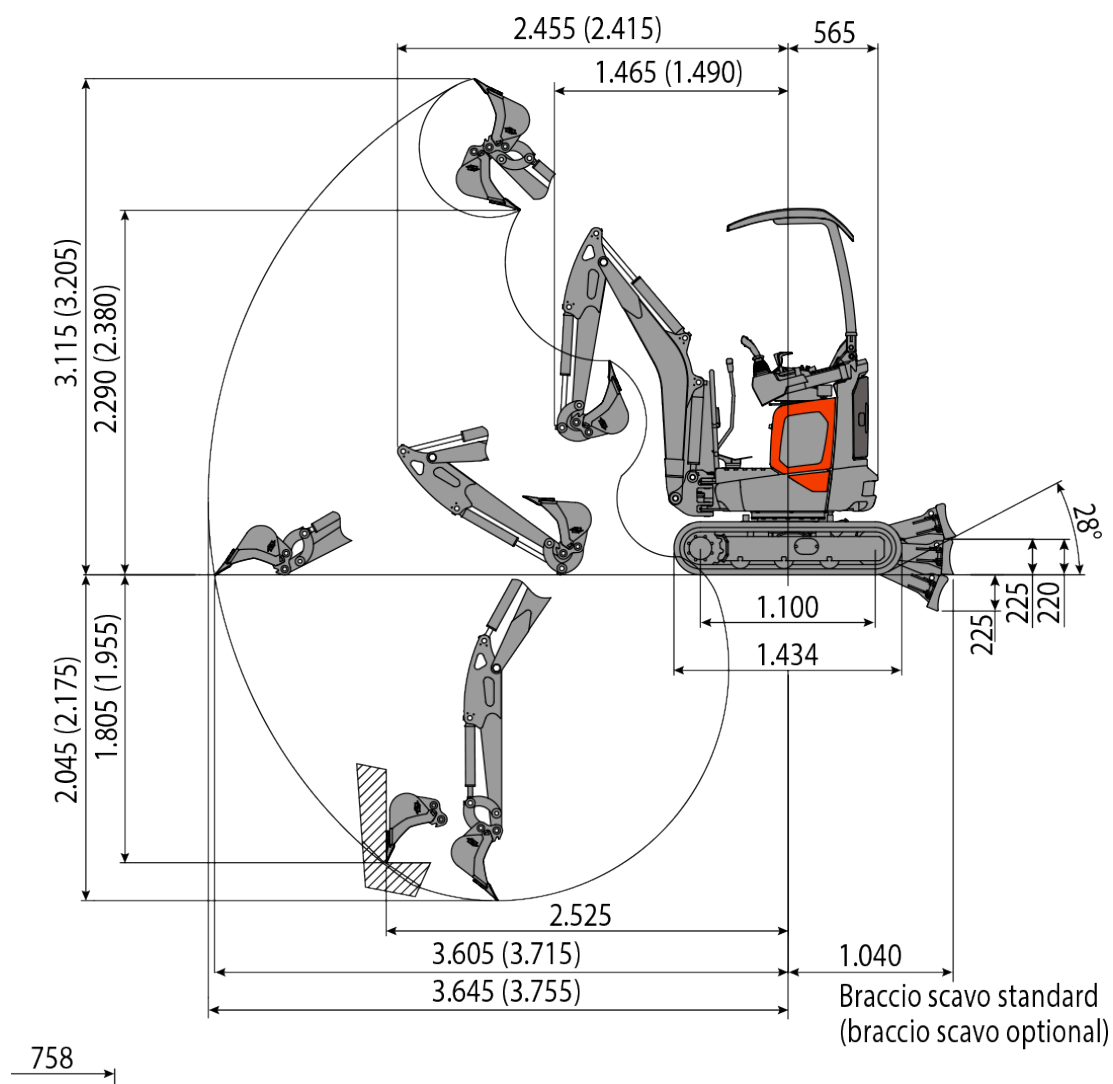

Escavatorie

Schema dimensioni

